

EVA

---



EXPERIENCE AND INNOVATION  
SINCE 1948

## INDEX

1	SYMBOLS USED .....	3
1.1	SYMBOLS USED IN THIS MANUAL .....	3
1.2	SYMBOLS USED IN LABELLING AND ON PACKAGING .....	3
2	INTENDED USE.....	4
2.1	INTENDED USER .....	4
2.1.1	Professional qualification:.....	4
2.1.2	Minimum competences .....	4
2.1.3	Experience .....	4
2.1.4	Possible user handicaps .....	4
3	PRODUCT DESCRIPTION .....	4
3.1	DESCRIPTION OF THE USER INTERFACE .....	5
3.1.1	Standard lamp.....	5
3.1.2	Lamp with Camera.....	5
4	INSTRUCTIONS FOR USE.....	6
4.1	SWITCHING ON/OFF .....	6
4.2	ADJUSTING LIGHT INTENSITY .....	6
4.3	CHANGING THE COLOUR TEMPERATURE ON THE TUNABLE WHITE VERSION.....	7
4.4	COMPOSAVE SETTING ON TUNABLE WHITE VERSION.....	7
4.5	MINIMUM INTENSITY SETTING ON SUNLIGHT VERSION .....	7
4.6	AUTO-ON SETTING.....	8
4.7	SWITCHING THEIA ON/OFF .....	8
4.8	REMOTE CONTROL.....	8
4.9	SYNCHRONOUS MODE WITH LIGHTHOUSE LAMPS.....	8
4.10	IMAGE FOCUS ADJUSTMENT .....	8
5	PREVENTIVE MAINTENANCE AND ROUTINE CHECKS .....	9
6	CLEANING AND DISINFECTION.....	10
6.1	CLEANING THE REFLECTORS.....	10
6.2	HEAD CLEANING AND DISINFECTION.....	10
6.3	CLEANING AND DISINFECTION OF ARMS .....	10
7	STERILISATION OF HANDLES.....	10
7.1	REMOVAL OF HANDLES.....	10
7.2	DECONTAMINATION AND DISINFECTION .....	10
7.3	STERILISATION.....	10
8	TROUBLESHOOTING.....	11
8.1	LIST OF ERRORS.....	11
9	TECHNICAL SPECIFICATIONS .....	12
9.1	STORAGE AND TRANSPORT: ENVIRONMENTAL CONDITIONS .....	13
9.2	USE: ENVIRONMENTAL CONDITIONS.....	13

Dear Customer,

FARO wishes you success with the new high quality EVA Dental Lamp.

To work safely and to take full advantage of the product's performance, please read this manual carefully before using the device. In particular, please follow all warnings and notes described in the Safety Recommendations included in the package.

#### Warranty Conditions:

FARO offers the end customer a 24-month warranty from the date of installation up to a maximum of 30 months from the date of manufacture.

Warranty repairs must be carried out by FARO or its approved service network.

The guarantee is considered valid only when:

- the user has sent the duly completed Certificate of Warranty to the following e-mail address: service@faro.it

- the user registered the guarantee via the Faro website or the Faro Tech APP;

The guarantee covers manufacturing and engineering defects; in the event of a valid claim, the guarantee only covers the free replacement of parts. Manual work is not included in the guarantee.





The guarantee shall not be considered valid, at FARO's sole discretion, if the defect is due to tampering, damage, unauthorised modifications to the product, improper use, incorrect maintenance and normal wear and tear.

This product has a service life of: 10 years.

Any serious accident occurring in connection with the device must be reported to the manufacturer and to the competent authority of the Member State in which the user and/or patient is established.

## 1 SYMBOLS USED

### 1.1 SYMBOLS USED IN THIS MANUAL

	<b>WARNING</b>
Sections marked with this symbol contain instructions that must be followed carefully to avoid damaging the device, causing harm to the operator or patient.	
	<b>ATTENTION</b>
This icon warns that care must be taken to avoid situations that could damage the device.	
	<b>PROHIBITION</b>
This icon highlights what not to do to avoid damaging the device and causing harm to user and patient.	
	<b>NOTES</b>
This icon provides information that allows you to use the device more efficiently.	

### 1.2 SYMBOLS USED IN LABELLING AND ON PACKAGING

The main nameplate is affixed:

- for the lamp or complete arms: on the rear arm

- for the lamp head: under the heat sink cover



























Serial Number Description

- For dental lamp YYLDNNNN (YY: last two digits of year of manufacture, NNNNN: progressive year counter)

- For the dental lamp head YTTENNNN (YY: last two digits of the year of manufacture, NNNN: progressive year counter)

for example: 2ILD000001 represents the serial number of the first device manufactured in 2021.

The following harmonised symbols are also present:

Symbol	Description	Symbol	Description	Symbol	Description
	European Conformity Mark		Can be steam sterilised at 134°C		Fragile
	Medical Device according to Reg (EU) 2017/745 of 5 April 2017.		Use the device at a temperature between 10°C and 40°C		Protect packaging from rain and high humidity
	Read the instructions for use. Supplied electronically.		Use the device at a pressure between 80 kPa and 106 kPa		Do not roll
	Manufacturer symbol according to Regulation (EU) 2017/745		Use the device at a relative humidity between 30 RH and 75RH		Do not use hooks
	Instructions for use include safety warnings		Symbol for switching the light on/off		Maximum stackable weight
	WEEE equipment according to Directive 2012/19/EC.		Light on/off symbol on the rear arm (Theia Tech)		Storage and transport temperatures
	Double insulation. Class 2 device against electrical hazards		Symbol for adjusting light intensity		Relative humidity during storage and transport
	Serial number		High		Storage and transport atmospheric pressure
	Swiss Mandate for the MedDo Medical Devices Regulation				Recyclable cardboard

## 2 INTENDED USE

The device is used in the dental office and is intended to illuminate the oral cavity and oral structures of dental patients. In normal use, the device is positioned at a distance of 700 mm from the operating area, the distance for which the lighting features were designed. Patients can be of all ages with typical dental pathologies.

### 2.1 INTENDED USER

The intended users are dentists, dental practitioners (all specialisations) or dental assistants

#### 2.1.1 Professional qualification:

Medical degree with specialisation in dentistry  
Degree in Dentistry  
Degree in dental hygiene

#### 2.1.2 Minimum skills

Those envisaged for the professional qualification  
Language comprehension: Those acquired for the professional qualification

#### 2.1.3 Experience

Those outlined for carrying out the profession

#### 2.1.4 Possible user disabilities

At least one upper limb is required for use;  
Visual faculty compatible with the profession;  
The user with these characteristics requires no special training

## 3 PRODUCT DESCRIPTION

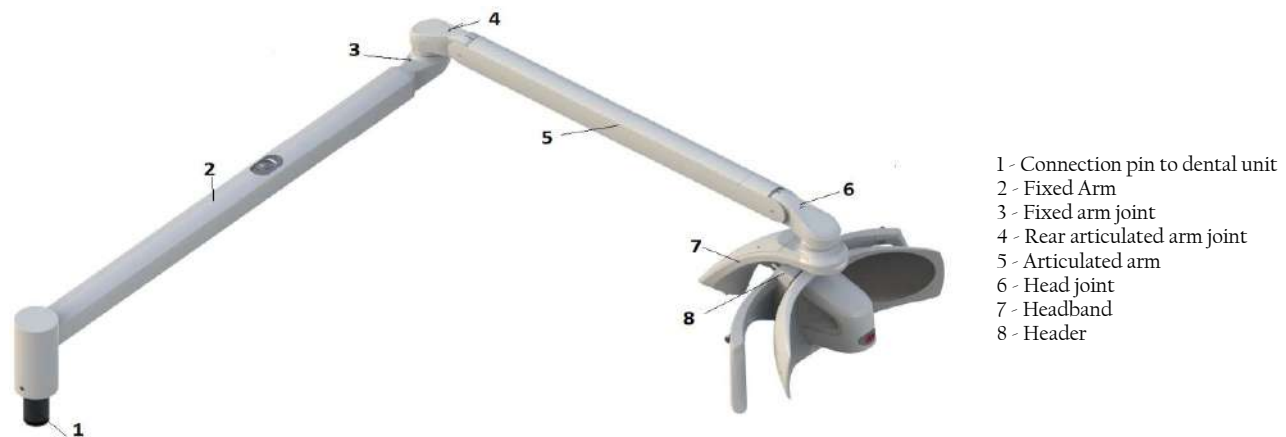

Image 1 - Dental lamp - dental unit mounting



Image 2 - Dental lamp - Ceiling mounting

The device is available in two main product variants:

- EVA with 5000 K light source with 'Sunlight' spectrum
- EVA with variable white colour temperature light source (4000 K, 5000 K, 5700 K, Composave setting (2700 K)) selectable by the operator (Tunable White).

These main variants can be supplied with:

- different Assembly;
- Different arm length combinations
- Canbus technology
- Remote cable to bring the control to the dental unit
- Automatic switch-on setting;
- Theia technology (secondary light source under the fixed arm);
- Integrated 4K camera;
- stud diameter

All variants can be ordered with dedicated product codes as shown in the table below:

Assembly		Articulated Arm		Fixed Arm		Light source / Integrated camera		Command / Rediofrequency (RF)		Wiring		Custom <sup>(1)</sup>	
1-2 DIGIT		3 <sup>o</sup> DIGIT		4TH DIGIT		5THDIGIT		6 <sup>o</sup> DIGIT		7TH DIGIT		8TH-9TH DIGIT	
5	U	0	Header only No Arm	0	Header only No Arm	0	Tunable White	0	Joystick	0	Power supply	00	Std lighthou se
5	C	1	550 mm column ø 45 mm	1	600 mm	1	Sunlight 5000K	2	Sensor	1	Power supply Remote Cable Bus cable	JJ	(4)
5	T	2	855 mm column ø 45 mm	3	820 mm	4	cNus Tunable White <sup>(2) (3)</sup>						
		6	550mm column ø 60 mm	4	820 mm Theia	5	cNus Sunlight 5000K <sup>(2) (3)</sup>						
		7	855mm column ø 60 mm	5	960 mm	6	CE Tunable White 4K Camera						
				6	960 mm Theia	7	CE Sunlight 4K Camera						

U: UNIT MOUNTING C: CEILING MOUNTING T: HEADER ONLY  
 (1) Customised codes only include aesthetic customisations that do not impact on Safety and EMC requirements  
 (2) The cNus mark for North America cannot be combined with the following variant codes:  
 Digit 1-2: 5T  
 Digit 3: 0  
 Digit 5: 6 and 7  
 (3) Ceiling-mounted versions with the cNus mark are considered fixed applications and must be connected to earth protection. These devices are Insulation Class I according to IEC 60601-1.  
 (4) Aesthetic customisation and branding do not affect safety and performance requirements

### 3.1 DESCRIPTION OF THE USER INTERFACE

#### 3.1.1 Standard lamp

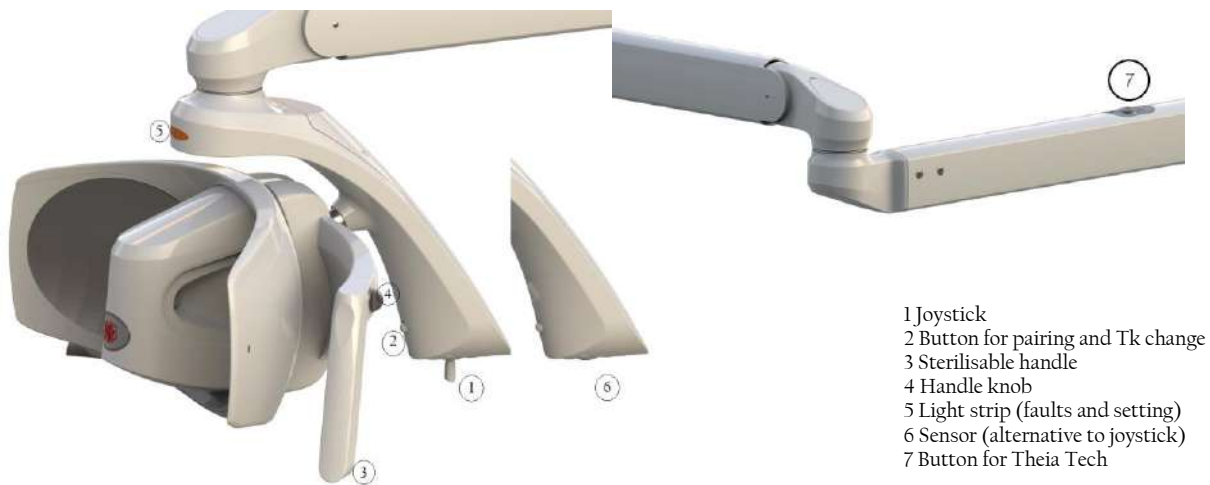





#### 3.1.2 Lamp with Camera



## 4 INSTRUCTIONS FOR USE

The device must be cleaned before use (see section Cleaning the device).

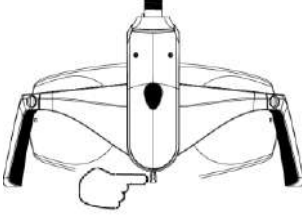
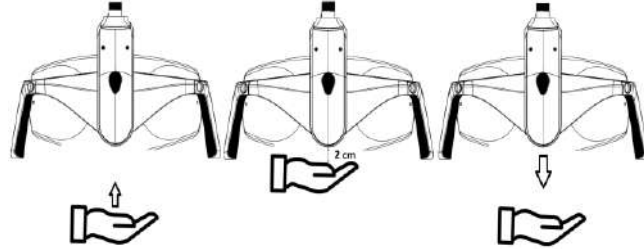

	<b>WARNING</b> Do not use the device in flammable or explosive environments Simultaneous use of the lamp with electrosurgical devices may cause malfunctions (flickering, lack of control, etc.).
	<b>PROHIBITION</b> The joystick must be handled with care to avoid breakage. Never move the lamp using the socket switch.
	<b>NOTE</b> When switched on, the device does a self-diagnosis, and the light strip starts flashing in different colours: blue, green and red. The following parameters are stored by the lamp and made available each time it is switched on: - last light intensity setting - Setting the light colour temperature (for the Tunable White variant)
	<b>WARNING</b> Do not use the device if parts or enclosures are damaged or if there is play or breaks between: - Header joint / Header bow - Fixed arm joint / Articulated arm joint

### 4.1 ON/OFF

Joystick	SensorE
	
Press right or left and release Acoustic signal: 1 beep	Bring your hand towards the sensor up to 2 cm and move it downwards Acoustic signal: 1 beep

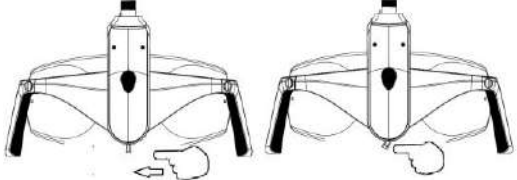
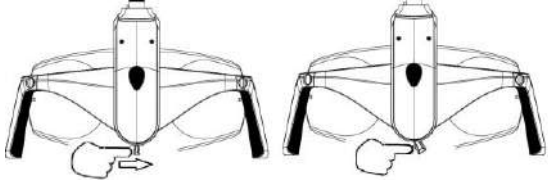
### 4.2 ADJUSTING LIGHT INTENSITY

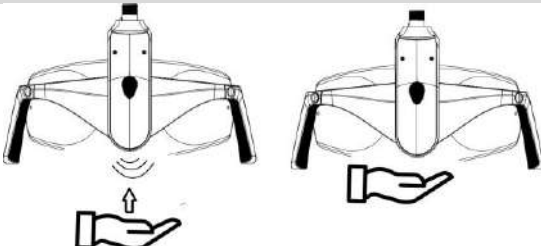
Joystick Increase light intensity	Joystick Decrease light intensity
	
Push to the left and hold until the desired intensity is reached. Then release Acoustic signal: 1 beep at command Maximum intensity reached: continuous acoustic signal	Push to the right and hold until the desired intensity is reached, then release. Acoustic signal: 1 beep at command Minimum intensity reached: continuous beep

Sensor - Increase and decrease light intensity	
	Bring your hand towards the sensor up to 2 cm and maintain this distance until the desired light intensity is reached Acoustic signal: 1 beep at command Maximum intensity reached: 2 beeps Minimum intensity reached: 1 beep
	in the sensor version the light intensity changes continuously by decreasing to the minimum and increasing to the maximum

when changing the light intensity, the indicator light changes according to the lighting level, according to the pictures below:

 Light intensity: Minimum	Light intensity: Medium Minimum	Light intensity: Medium Maximum	Light intensity: Massimo
			

### 4.3 CHANGING THE COLOUR TEMPERATURE ON THE TUNABLE WHITE VERSION

Joystick and Sensor

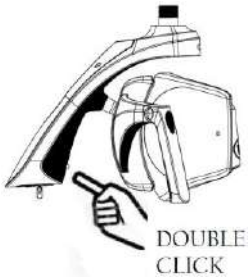

Each time a double-click is performed, the Tk of the light changes.  
Repeat the procedure until the desired colour temperature is displayed on the indicator light.  
2 beeps will inform the user that the Tk is changing.



If the double click is too fast, the lamp may not take the colour temperature change command. In case repeat the operation

Sunlight version	Tunable White version		
TK 5000 K Green indicator light	TK 4000 K Yellow indicator light	TK 5000 K White indicator light	TK 5700 K Blue indicator light

### 4.4 COMPOSIVE SETTING ON TUNABLE WHITE VERSION

The composave setting allows the user to work while avoiding the polymerisation of composite materials.  
Select the composave setting as described below:

Joystick option 1	Joystick option 1	Luminous Indication		
 Press and release	 SINGLE CLICK			
<th>Sensor</th>	Sensor	<th>Visual information</th>	Visual information	
 SINGLE CLICK				



When the dial command is selected, an intermittent beep is heard.  
The light intensity of the composave is not adjustable.  
The indicator strip changes to orange.



Exit the Composave Setting with a single click.  
This operation is necessary to return to the other settings.

### 4.5 MINIMUM INTENSITY SETTING ON SUNLIGHT VERSION

Joystick	Sensor	Visual information
 Press and release	 SINGLE CLICK	
Press and release the joystick Forward or Reverse	Press and release the button on the headband	Minimum intensity sector illuminated.



To exit the setting, a single click takes you back to the previous lighting

#### 4.6 AUTO-ON SETTING

When the switch-on mode is set to Auto-on, the lamps switch on automatically (without a specific command from the user) in the presence of power from the dental unit.

The function can be activated via the FARO Tech APP, available on the Play Store and Apple Store.

#### 4.7 SWITCHING THEIA ON/OFF



The light on the fixed arm (secondary light) can be switched on/off and adjusted synchronously with the operating light and its control. The secondary light can be operated manually via the button (7) on the fixed arm.

If the secondary light is switched on after the operating light, it will be automatically synchronised.

If the secondary light is switched on with the operating light switched off, it will automatically be set to maximum intensity.



The light on the fixed arm is adjusted synchronously with the operating light, it cannot be adjusted independently.

Synchronisation can be disabled via the FARO Tech APP, available on the Play Store and Apple Store.

#### 4.8 REMOTE CONTROL

Refer to the dental unit instructions for operating the dental lamp via the dental unit control panel.

#### 4.9 SYNCHRONOUS MODE WITH LIGHTHOUSE LAMPS

When present, the device can be connected by radio frequency (RF) to Faro's Ambient Lamps to create a synchronised lighting system.

The procedure for creating this connection is called 'pairing'.

If more than one ambient lamp is installed in the dental office, please ensure that the others are switched off or have not been switched on for more than 60 seconds.

To activate 'Pairing', proceed as follows:

1. Switch on the ambient lamp. This will start to seek input from the dental lamp for a duration of 60 seconds.
2. Within 60 seconds, press the 'Pairing' button on the dental lamp. The button should be held down between 4 and 6 seconds. Attention: If the button is held down for more than 6 seconds, the procedure will be cancelled.

On the Ambient Lamp, the blue LED on the aluminium housing is activated.



If the blue LED does not light up, another attempt can be made within 60 seconds of the first one. If 60 seconds elapse after the Ambient lamp is switched on, the procedure from step 1 must be repeated.

3. After the blue LED lights up, there are 60 seconds to confirm 'Pairing' by pressing the programming button on the room light remote control. At this point, the blue LED on the room light flashes twice and then goes out. If the button on the remote controls is not pressed within 60 seconds, the blue LED goes out and the procedure must be repeated from step 1.

After 'Pairing', synchronisation between the 2 lamps (dental lamp and room lamp) is enabled.

To DEACTIVATE THE SYNCHRONIZATION FUNCTION, proceed as follows:

Press the Synchro button for 2 to 4 seconds, then release it.

Upon release, an audible signal will be heard and the blue LED of the Room Light lamp will turn off to indicate that synchronisation has been deactivated.

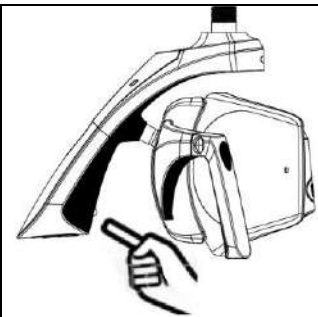

When the Room Lamp is synchronised with the Dental Lamp the blue LED on the Room Lamp is lit steadily. If the LED goes out, this indicates that synchronisation is not active.

The remote control is always enabled, so it is possible to change the lighting value in manual mode.

If the Dental Lamp is switched off, the Room Lamp remains switched on.

#### 4.10 IMAGE FOCUS ADJUSTMENT

The image can be focused manually by adjusting the camera focus via the ring nut.

Zoom in: turn the bezel anti-clockwise (blue arrow in the picture)

Zoom out: turn the dial clockwise (red arrow in the picture)



##### WARNING

Do not force rotation beyond the limit switch to avoid damage to the rotation system







## 5 PREVENTIVE MAINTENANCE AND ROUTINE CHECKS



Only a trained technician is authorised to perform corrective maintenance and replacement of any part of the device, according to the manufacturer's service manual.

Control	Frequency	Procedure	Responsibility
No play or gap between the joining points (points 1, 2, 3, 4)	12 months		specialist technician
The screws of the connection points must be tight and undamaged: - screw 5 - Screw 6.	12 months		specialist technician
The ferrules under casings 1, 2 must be well secured and the safety screws must be intact. The screws under casing 3 must be tight and undamaged.	12 months		specialist technician
Check joints, arms or plastic parts for oxidation.	12 months	Visual inspection	specialist technician
Check that the main label is legible	12 months	Visual inspection	specialist technician
Absence of damage to the casing and verification of the integrity of plastic and metal parts	12 months	Visual inspection	specialist technician
Electrical safety according to EN 62353	24 months	Use the parameters defined in IEC 60601-1	specialist technician
Light quality controls	24 months	Using a spectroradiometer, check the values for: Maximum luminance: >35000 lux CRI > 85 Radial power on blue light: <100 W/m <sup>2</sup>	specialist technician

## 6 CLEANING AND DISINFECTION

	<p><b>Warning against corrosion due to the risk of falling masses</b></p> <p>For all metal or plastic parts, it is strictly forbidden to use substances that are</p> <ul style="list-style-type: none"> <li>- abrasive,</li> <li>- corrosive,</li> <li>- acids,</li> <li>- substances containing chlorine or chloride ions, phosphorus or phosphorous ions,</li> <li>- Trilene-based detergents, petrol, white spirit, chlorine or similar.</li> </ul> <p>Do not use detergent-disinfectants containing the following substances to clean plastic parts:</p> <ul style="list-style-type: none"> <li>- Ammonium hydroxide</li> <li>- Sodium hydroxide</li> <li>- Hydrogen peroxide</li> <li>- Ammonium chloride</li> <li>- Methylene chloride</li> <li>- Methyl alcohol</li> <li>- Acids and corrosive substances of all kinds.</li> </ul> <p>It is forbidden to spray any chemical substance directly onto the device. The use of wet wipes without rinsing is prohibited.</p>
	<p>Faro has tested and recommends the use of the following disinfectants for plastic and metal parts:</p> <ul style="list-style-type: none"> <li>- Durr FD366 Sensitive</li> <li>- Perflex Advanced Lighthouse</li> <li>- Disinfectants based on water and alcohol with 70% isopropyl alcohol or ethanol are suitable.</li> </ul>

### 6.1 CLEANING THE REFLECTORS

Cleaning should be done with a soft cotton cloth or absorbent cotton with ethyl alcohol.  
Alcohol-water disinfectants are suitable with 70% isopropyl alcohol or ethanol.

	<p><b>Caution - risk of damage to reflectors</b></p> <p>Never spray the cleaner directly onto the dishes. Cleaning of dishes must be carried out wearing gloves to avoid leaving marks on surfaces. Never use cleaning agents containing surfactants or water repellents, which can leave streaks when deposited. Slight streaks do not impair the quality of light. Products other than those suggested could damage the dishes. In case of doubt, please contact FARO customer service.</p>
---	---

### 6.2 HEAD CLEANING AND DISINFECTION

Cleaning should be done with a soft cotton cloth moistened with a disinfectant solution.  
Always wring out the cloth to remove all excess liquid.

### 6.3 CLEANING AND DISINFECTION OF ARMS

Always use a cloth soaked in approved disinfectant to disinfect surfaces and wipe with it.  
Always wring out the cloth to remove all excess liquid.

## 7 STERILISATION OF HANDLES

	<p><b>Danger of cross-contamination warning</b></p> <p>The handles are not supplied sterile, they must therefore be sterilised before use. The handles must be sterilised before each patient.</p>
---	--

### 7.1 REMOVAL OF HANDLES

To remove the handle, unscrew knob 'A' and pull the handle out of the holder.

### 7.2 DECONTAMINATION AND DISINFECTION

Before sterilising handles, they must be decontaminated and disinfected.

For disinfection, Faro tested the following products:

Faro Perflex Advance

Durr FD366 Sensitive

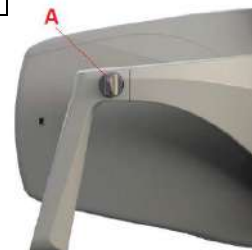

	<p><b>WARNING - danger of breaking plastic</b></p> <p>Handles cannot be disinfected by thermosdisinfection.</p>
---	---

### 7.3 STERILISATION

Handles must be bagged in accordance with EN 868-5.







Handles can be sterilised with standard 121°/134° C cycles up to two hundred (200) cycles or until loss of mechanical performance.

The parameters of the sterilisation cycle are as follows:

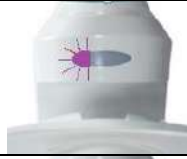

Cycle EN 13060	Temperature	Pressure	Minimum Holding Time
B	121°C	207 kPa	15 min
B	134°C	308 kPa	3 min

## 8 TROUBLESHOOTING

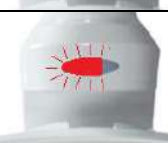
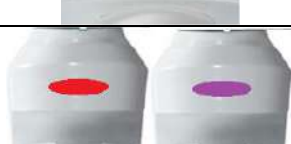
### 8.1 LIST OF ERRORS

Error	Description	Indicator light	Strip light colouring	Acoustics Information
E1	Active overtemperature protection	First sector flashing. Colour set: VIOLET		3 prolonged beeps
E2	High temperature on the board	All sectors flash in sequence. Colour set: VIOLET		3 prolonged beeps
E5	Open Led circuit channel 1	First sector flashing. Set colour: RED		3 short beeps repeated 3 times
E6	Open Led Circuit Channel 2	First and second sector flashing Set colour: RED		
E8 E9	Low input voltage High input voltage	All sectors flash together Set colour: RED		5 prolonged beeps
E10	Communication with RGB board	The luminous gem is extinguished		Switch off the lamp for 60 s and switch it on again
E11	Open LED circuit channel 1 and channel 2	First. Second and third sector flashing. Set colour: RED		3 short beeps repeated 3 times
N.C.	None	The luminous gem remains stuck on a colour		Switch off the lamp for 60 s and switch it on again

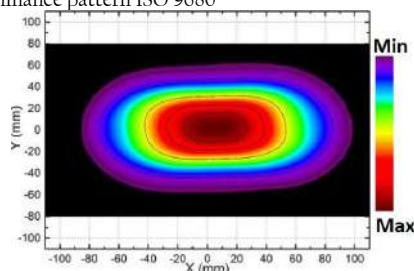
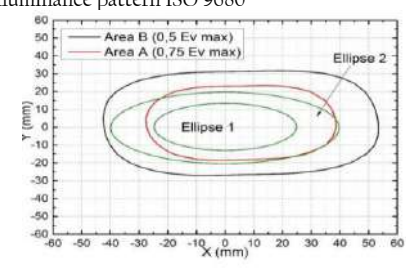
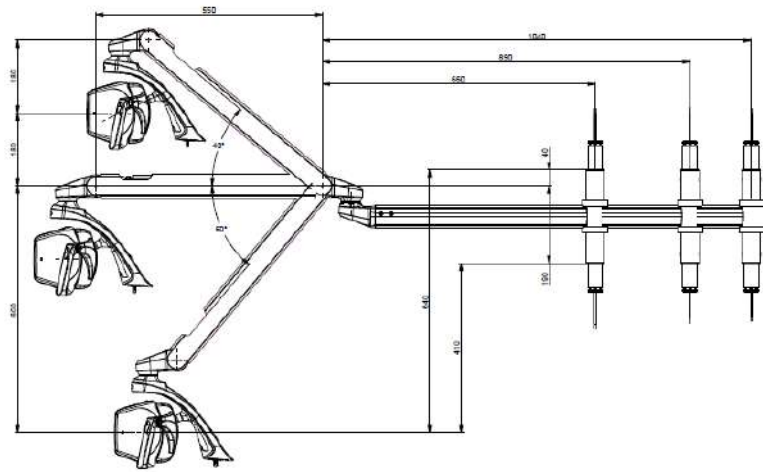
### 9 TECHNICAL SPECIFICATIONS

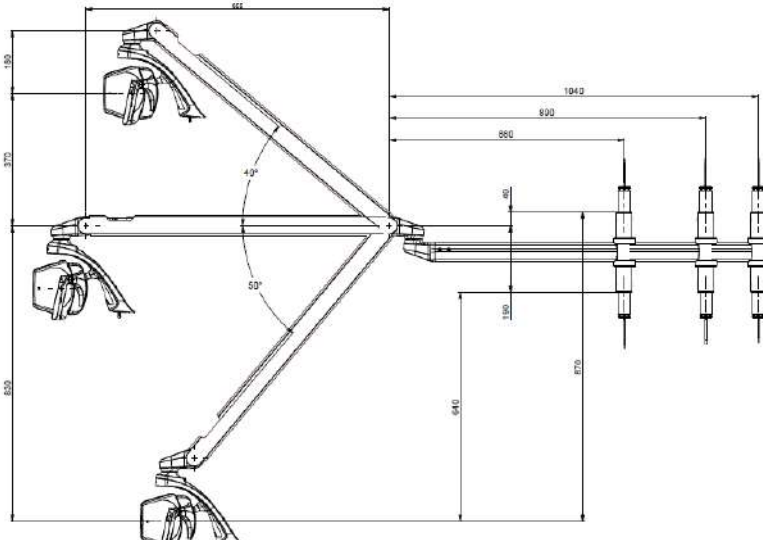
	Dental Lamp Dental Lamp Head	Dental Lamp with Secondary Light (Theia)
Supply Voltage	24 V ac ±10% 50/ 60Hz; 32 V dc ±10%;	24V ac ±10% -50/60 Hz; 32 V dc ±10%;
Supply voltage Camera	5 Vdc via USB 2	
Room performance	4K, 30 fps (video), 8 Mpx still	
Maximum Power Absorption:	24 V ac 26 VA 32 V dc 14 VA	24 V ac: 40 VA 32 V dc: 28 VA
Recommended fuses for installation (not supplied by installer)	24 V ac T1.6AL 250V 32 V dc T1.25AL 250V	24 V ac: T2AL 250V 32 V dc: T1.25AL250V
Protection against electrical risk NB: the final classification of the protection class of the medical system is requested from the installation technician or manufacturer.	Class II Class I for ceiling mounting for Canada US certification	
IEC Classification 62471	Class I - Labelling Exempt	
Maximum Illuminance	50,000 lux (*)	
Colour Rendering Index (*)	> 95 (*)	
Correlated Colour Temperature CCT (*)	Sunlight 5,000 K Tunable White: 4000 K - 5000 K - 5700 K Composave: 2700 K	
Spot Dimension (*)	180 mm x 110 mm	
Max Hard Shadow ISO 9680 (*)	10 mm x 5 mm	
Nature of radiation	Non-ionising	
Type of radiation	Visible light	
Typical illuminance pattern ISO 9680	Typical illuminance pattern ISO 9680	
		
General movements and overall dimensions 550 mm articulated arm (dental unit and ceiling version)	Header rotations	
		
General movements and overall dimensions articulated arm 855 mm (dental unit and ceiling version)		
		

(\*) Typical optical values subject to tolerances. Measurement taken at 700 mm distance. Contact Faro for correct measurement procedure.

## 9.1 STORAGE AND TRANSPORT: ENVIRONMENTAL CONDITIONS

The device in its original packaging can be transported and stored for up to 15 weeks if the following environmental conditions are met:

- Ambient temperature -20°C to +70°C
- Relative humidity from 10% to 90%.
- Atmospheric pressure from 50 kPa to 106 kPa

## 9.2 USE: ENVIRONMENTAL CONDITIONS

- The device must be used under the following environmental conditions:
- Temperature from 10° to 40°C
- Maximum altitude: 2000 m
- Relative humidity 30% to 75%



DAL 1948: ESPERIENZA  
E RINNOVAMENTO

 **FARO S.p.A.**

via Faro, 15 - 20876 Ornago (MB) - Italy

Tel. +39 039.68781 - Fax +39 039.6010540

[www.faro.it](http://www.faro.it) - [comm.italia@faro.it](mailto:comm.italia@faro.it) - [export@faro.it](mailto:export@faro.it)

**EVA**

**Dental Operating Light**

**Medical Device**

**Class I**

